

SPEC SHEETS

MODEL: BMF-21-1S

Vertical Reach In Freezer



Product features

- Digital Temperature Controller with automatic defrost function.
- Six epoxy coated shelves included.
- Corrosion Resistant stainless steel exterior and interior.
- Eco-Friendly R-290 Refrigerant.
- Self Closing doors.
- Door Locks.
- 4" Heavy duty Casters.
- LED Lighting.
- UL Safety and Sanitation Listed.
- Easy access to refrigeration system.

Material

- Food grade stainless steel

Accessories

- Additional shelves

Product Highlights



Digital Temperature Controller



4" Heavy Duty Casters



Epoxy Coated Shelves

Certifications



Warranty

- 2 year parts and labor
- Additional 3 year compressor coverage

Residential: Assumes on liability for parts or labor coverage for component failure, factory defect or any other damages for units installed in non-commercial foodservice or residential applications.

PRODUCT SPECIFICATIONS

MODEL: BMF-21-1S



Plan view

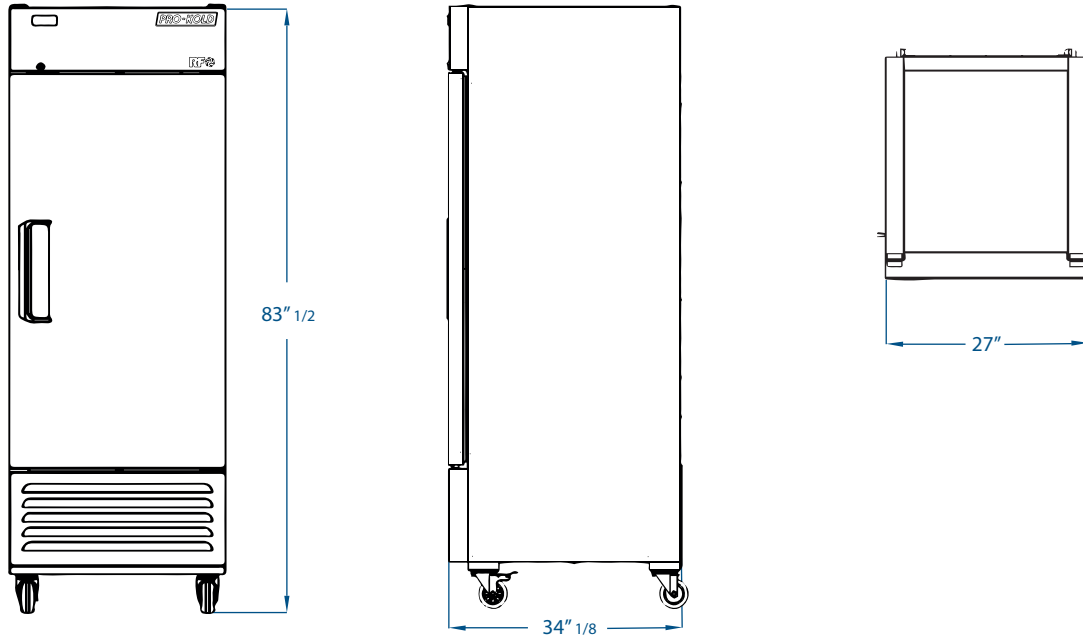

Technical data

Dimensions

External dimensions	W: 27", D: 34 1/8", H: 83 1/2"
Internal dimensions	W: 21", D: 28", H: 53"
Total volume	21 ft3 (595 L)
Net capacity	18 ft3 (546 L)
Net weight	287 lb (130 kg)
Gross weight	324 lb (147 kg)
Shelves Dimensions	W: 21 7/16" D: 23 5/16"

Performance data

Refrigerant charge	2.7oz
Energy consumption	4.8kW/24h
Evaporator	Forced ventilation
Expansion method	Capillary
Thawing method	Electric

Construction

Exterior material	Stainless steel and Galvanized steel
Interior material	Stainless steel
Number of shelves	3
Shelf material	Epoxy coated painted steel
Door type	Solid (Stainless steel)

*Height from the floor to the evap. housing.

Electrical data

Power supply	120 v/60 Hz
Amps	5.5A
Length of cord	2.9 m
Lighting	LED
Plug type	NEMA 5-15P
Controller	Electric
Voltage	115 V

Cooling

Temperature range	-0.4°F to -4°F
Refrigerant	R290
Cut In	1.4°F (-17 °c)
Cut Out	-6.5 °F (-21.38 °c)
Compressor power	1/2 Hp

Logistic data

53' Trailer Loads	48 units
Unit weight with packaging	322 lb (147) kg
Dimensions with packaging	W: 33" D: 38" H: 85"